

clever – creative – sustainable – smart



Vacuum Formed Products

utzgroup.com

THE COMPANY

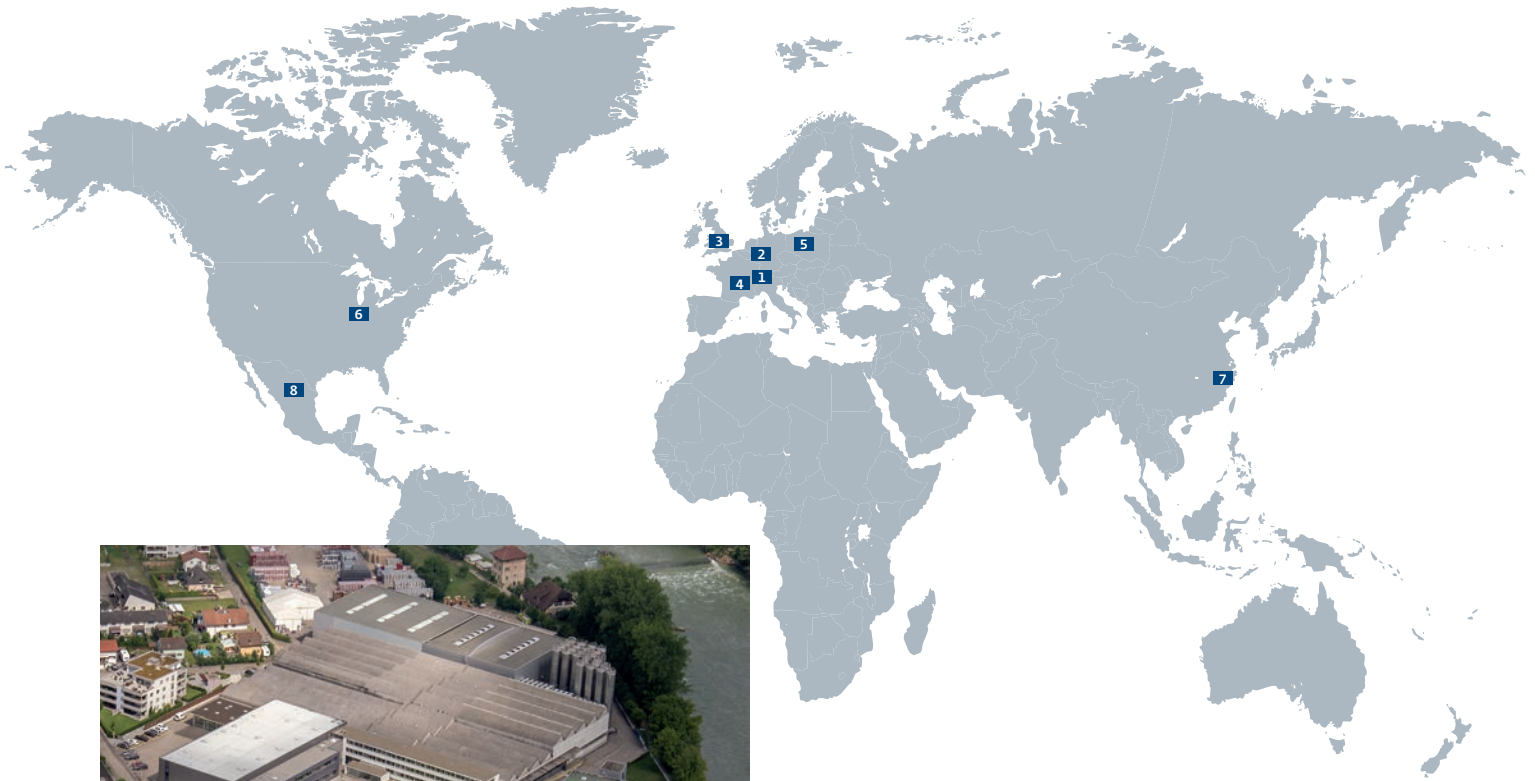

- 1 Georg Utz AG**
 Augraben 2-4 • 5620 Bremgarten • Switzerland
 Phone: +41 56 648 77 11 • Fax: +41 56 648 79 12
 E-Mail: info.ch@utzgroup.com
- 2 Georg Utz GmbH**
 Nordring 67 • 48465 Schüttorf • Germany
 Phone: +49 5923 805 0 • Fax: +49 5923 805 800
 E-Mail: info.de@utzgroup.com
- 3 George Utz Ltd.**
 Grange Close • Clover Nook Industrial Estate • DE55 4QT Alfreton, Derbyshire • UK
 Phone: +44 1773 543 170 • Fax: +44 1773 543 180
 E-Mail: info.uk@utzgroup.com
- 4 Georg Utz Sarl**
 Parc d'Activités les 2B • 405 Chemin des Vignes • 01360 Bressolles • France
 Phone: +33 4 37 85 83 00 • Fax: +33 4 37 85 83 09
 E-Mail: info.fr@utzgroup.com
- 5 Georg Utz Sp.z o.o.**
 ul Nowowiejska 34 • 55-080 Katy Wrocławskie • Poland
 Phone: +48 713 16 77 60 • Fax: +48 713 16 77 61
 E-Mail: info.pl@utzgroup.com
- 6 Georg Utz Inc.**
 14000 North 250 West • 46124 Edinburgh, IN • USA
 Phone: +1 812 526 2240 • Fax: +1 812 526 2428
 E-Mail: info.us@utzgroup.com
- 7 Georg Utz Materials Handling (Suzhou) Co., Ltd.**
 No. 698 Jianlin Road, SND • 215151 Suzhou City, Jiangsu Province • China
 Phone: +86 512 6616 0227 • Fax: +86 512 6616 0308
 E-Mail: info.cn@utzgroup.com
- 8 Georg Utz de México S. de R.L. de C.V.**
 Circ. Corral de Piedras 17 • San Miguel de Allende, Gto. 37888 • Mexico
 Phone: +52 415 120 5384
 E-Mail: info.mx@utzgroup.com

Georg Utz AG

manufactures storage and transport containers, pallets, component holders and technical parts consisting of recyclable plastics.

The production plant in Bremgarten in Aargau is the Swiss branch of Georg Utz Holding AG, also based in Bremgarten. Approximately 200 employees work at this location.

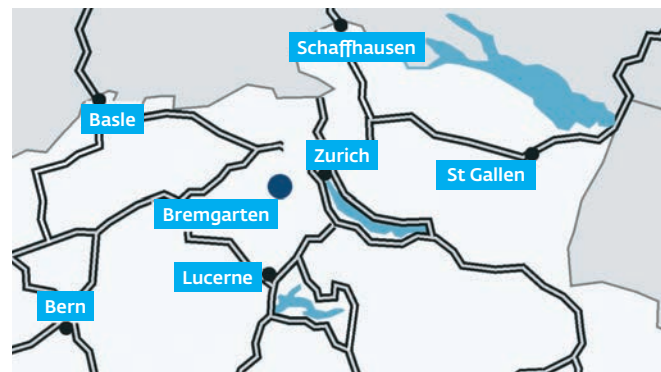

Why vacuum forming?

Important factors that lead to the decision for a vacuum formed component holders from Utz:

1. Tool costs

Moulds are cost-efficient. For just a few thousand Swiss francs, you will receive the product that is precisely tailored to your needs.

2. Schedule

A tool is quickly built, sampled and ready for serial production. Series are produced immediately after their release.

3. Technical characteristics

- Maximum mould area 1450 x 1200 mm
- Maximum height 600 mm
- Base material thickness 0.4 - 10 mm
- most commonly used materials: PS ABS, PC, PP, PE, PET-G, electrically conductive material and blends
- Material with anti-slip properties or special surfaces
- Colour according to your specifications (minimum quantities)
- fast and cost-effective modifications to existing vacuum forming moulds possible

Application

- in all sectors
- in automatic assembly machines and for robot handling
- also suitable for small series
- transport aids in modern logistics

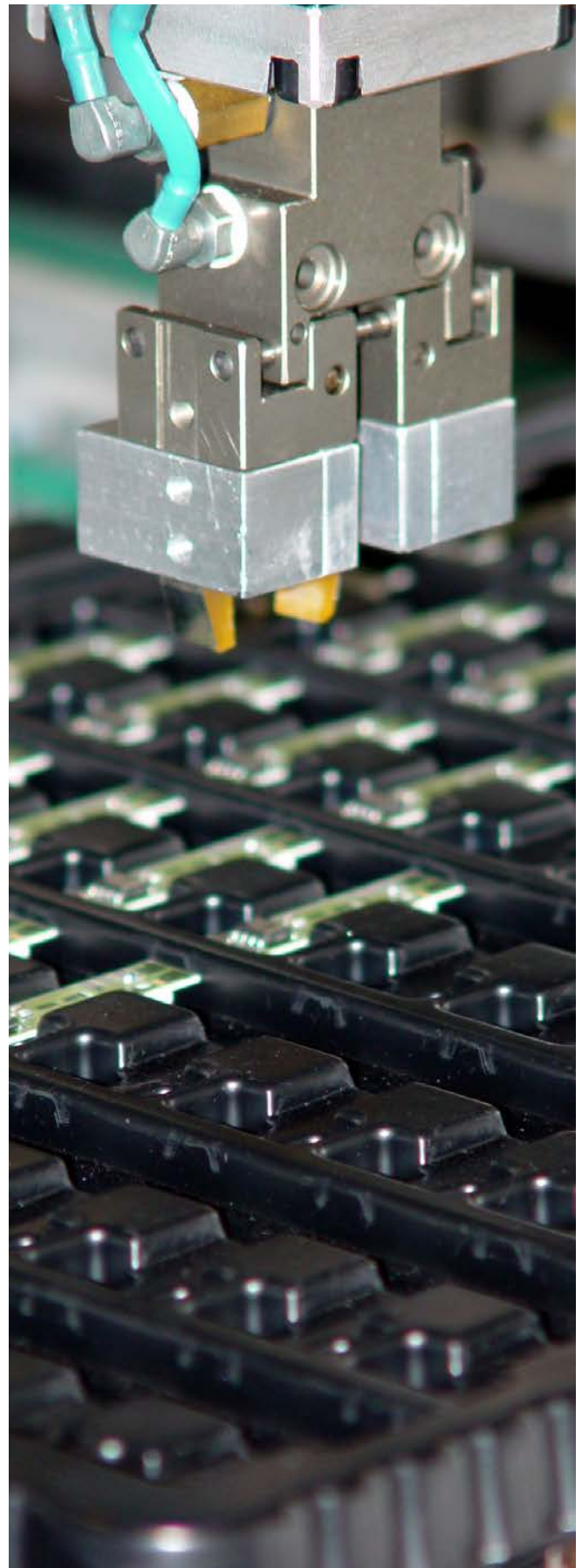

From the idea to the product



Requirement analysis

During a consultation, a checklist is used to record all requirements for the desired product in a requirement specification. This forms the basis for the drawing and the quotation.

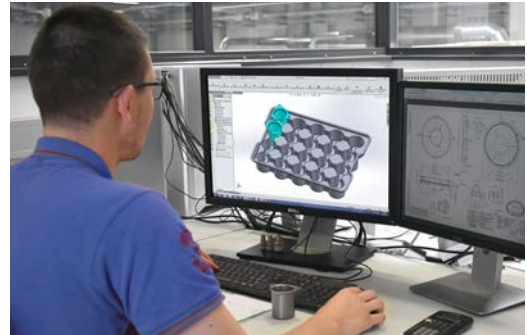

3D Display and proposal

The requirement specifications are also used to construct a 3D article for visualisation purposes.

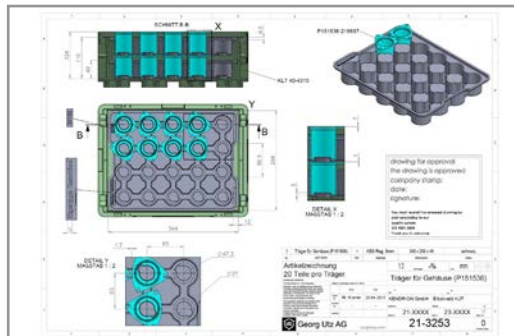

Article drawing



Mould cavity

Based on the 3D data, a mould cavity of the planned product can be created very quickly.



Tool constructions

Once all details are clarified and approved by the customer, the tool is manufactured, and initial samples are taken. The customer receives these parts together with the initial sampling test report.



Serial production

Serial production can commence once the customer has approved the initial samples.

From a plastic sheet to vacuum formed products

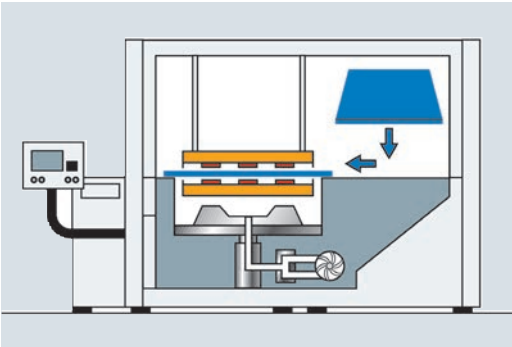

Heating process

A plate or film consisting of thermoplastic material is tightened in a tenter frame and heated with a suitable heat source up to and including the plastic area.

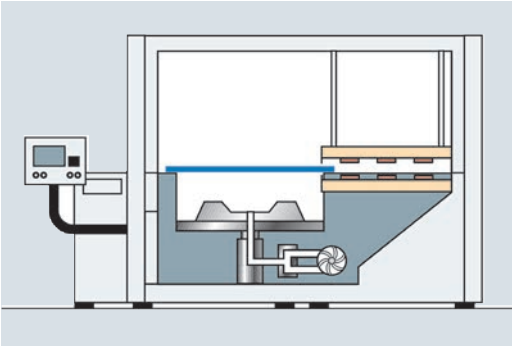

Start of the forming process

Once the plate is suitably heated to enable forming, the radiators are retracted.

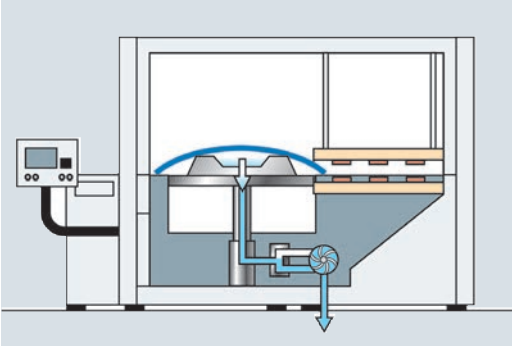

Forming: Creating a vacuum

The heated plate is pre-stretched by air pressure and the forming tool is driven to the pre-stretched plate. The air between the tool and the plate is aspirated (vacuum).

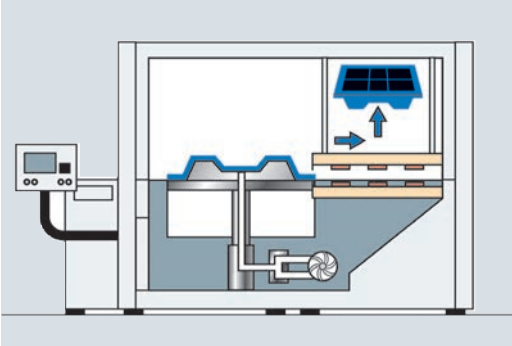

Finished!

The external atmospheric pressure pushes the soft plate to the mould wall to such an extent that the contours are accurately copied.

Vacuum formed product variety

Our most common products:



Frame tool carriers
Page: 7



Component holders, stackable
Page: 8



Component holders, rotary stackable
Page: 9



Component holders as interim layers
Page: 10



Vacuum formed containers
Page: 11



Blisters
Page: 12



Covers
Page: 13



Combined solutions and dividers
Page: 14



Transport units
Page: 15

Frame tool carriers

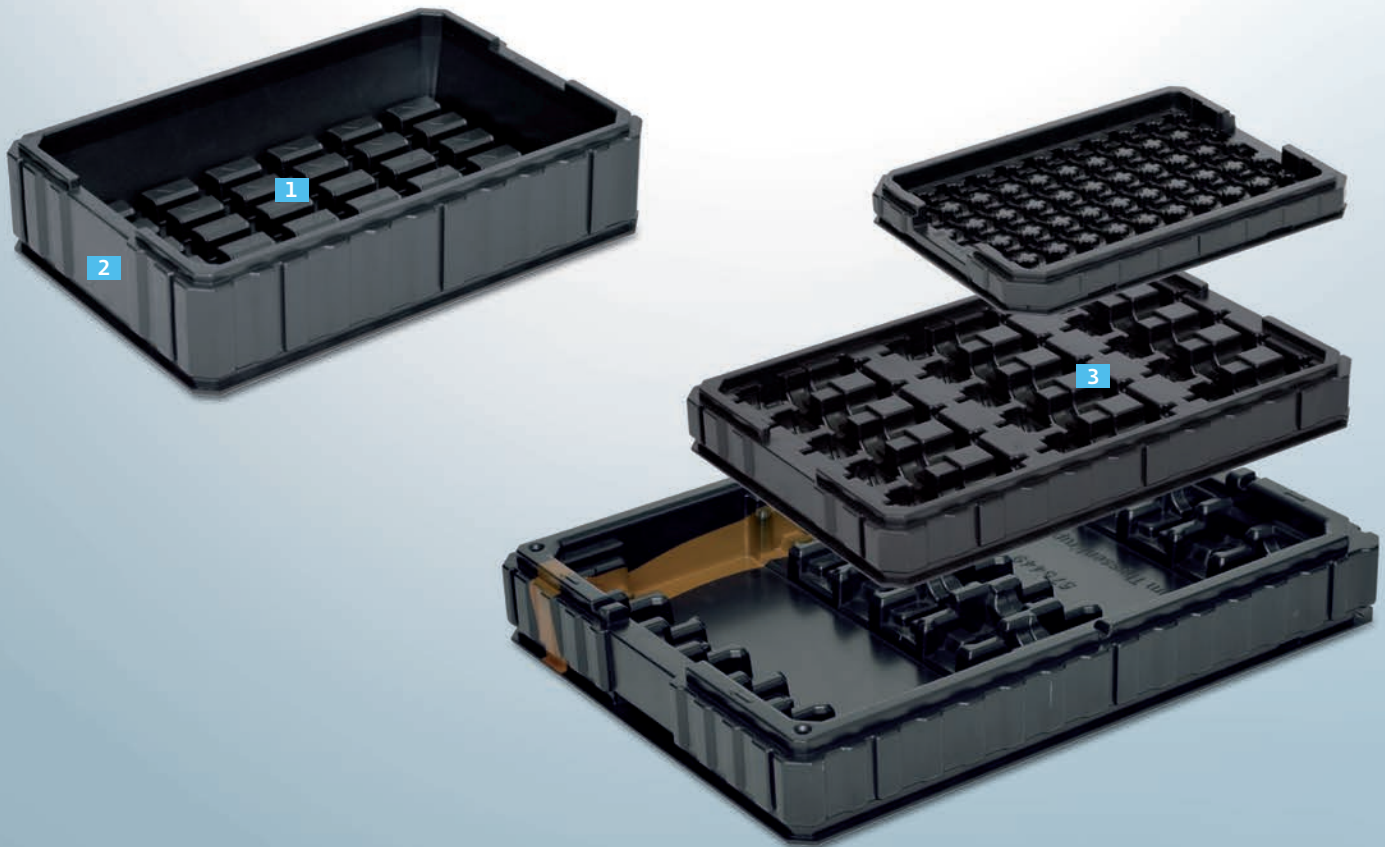

- 1 A customer-specifically designed inner moulded part ...
- 2 ... and a standardised and reusable frame tool at Utz ...
- 3 ... are merged to create a component holder that is individually standardised, both internally and externally.

The advantages of a frame tool system

- Out contour with centring devices, therefore
- optimal for automatic handling
- closed, dust-proof interior
- optimal stacking properties
- no additional packaging required
- matches pallet dimensions

Sizes:

400 x 300 mm
 600 x 400 mm
 600 x 500 mm
 800 x 400 mm
 800 x 600 mm
 additional sizes available upon request

Component holders, stackable



1

In containers

Component holders can be used in plastic containers for safe and dust-free transport and storage.

2

With handle recesses

If stackable component holders are transported in a container, handle recesses facilitate removal from the container.

3

With colour coding

Colour-coded component holders

4

Electrically conductive ESD

Component holders made of electrically conductive material.

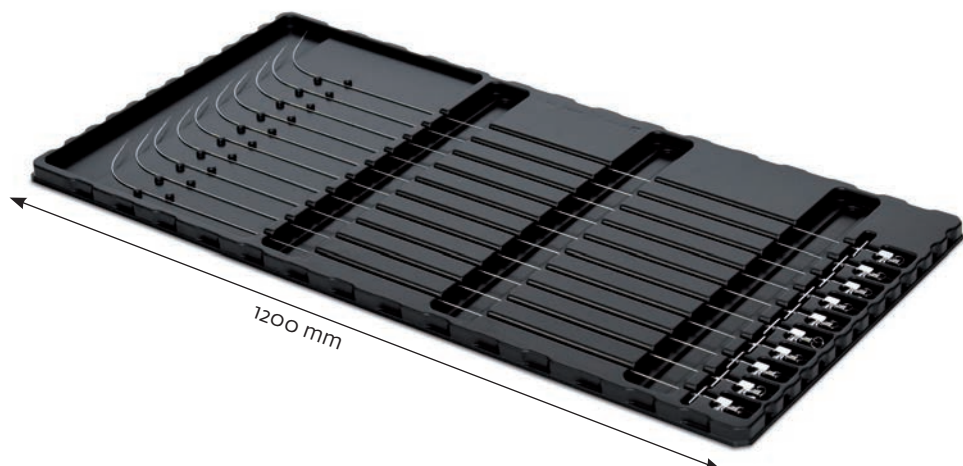

Component holders, rotary stackable

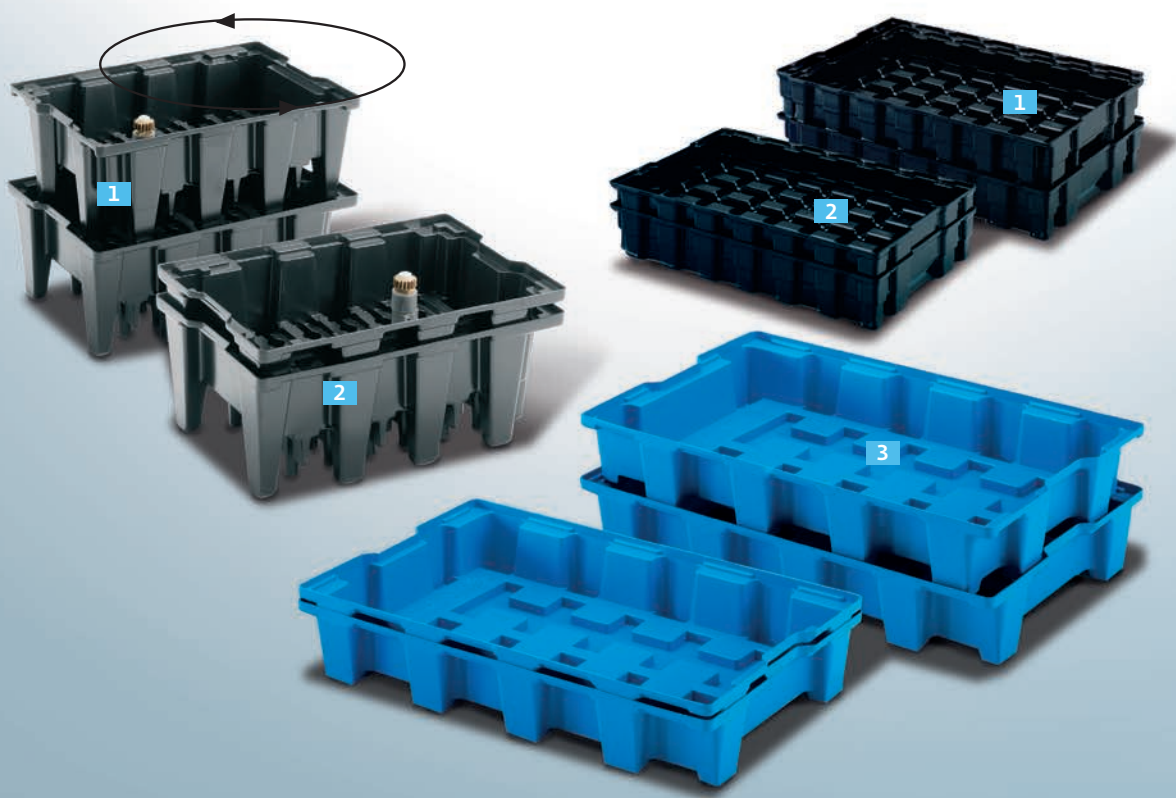

1
Stacking
Stecked position

2
Nesting
After a 180-degree rotation, the component holders can be nested into each other. Space savings of up to 80 %.

3
Consisting of coloured material
Different colours possible



Component holders as interim layers

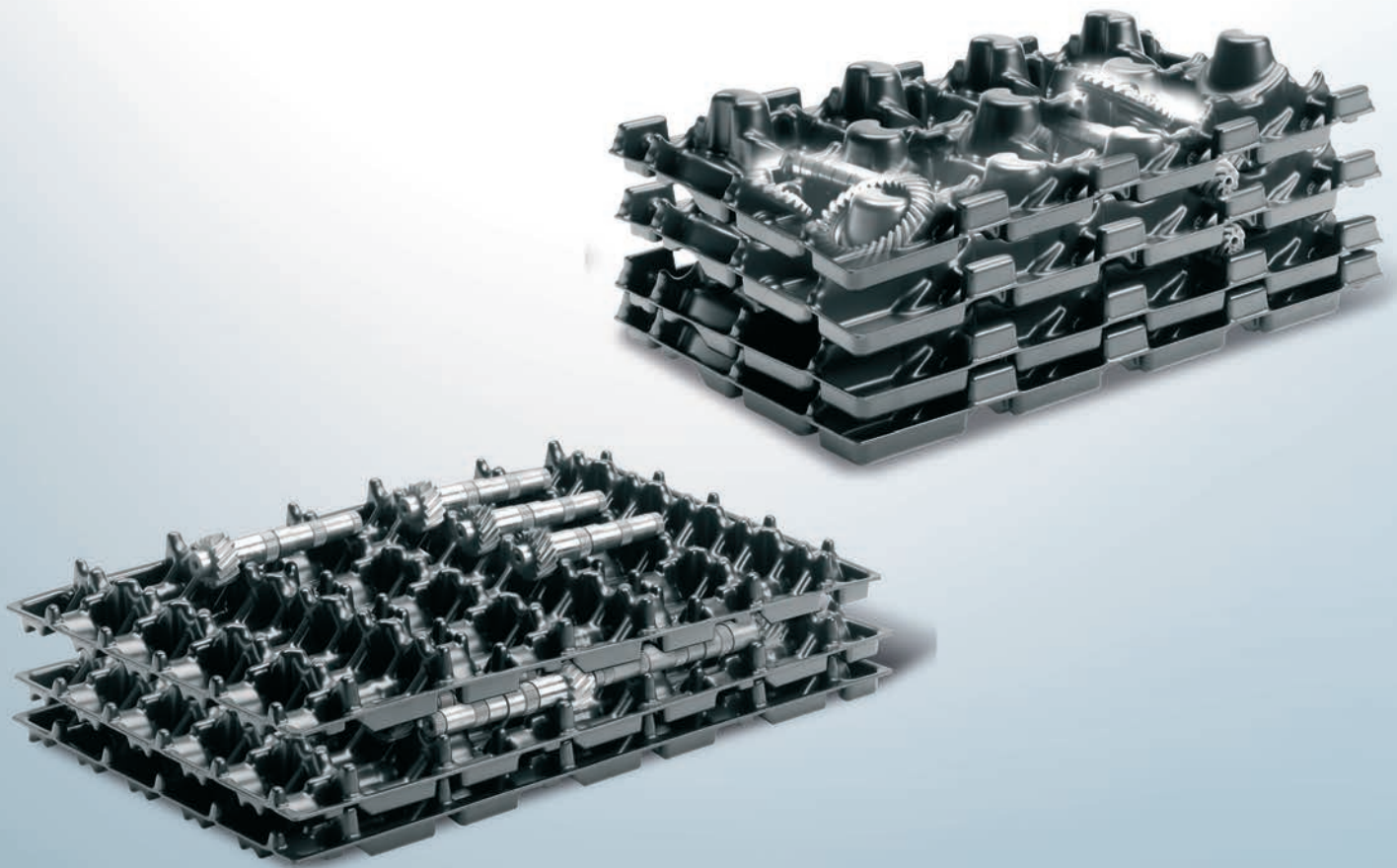

The Sandwich principle

The products to be packed are placed in the nests of a component holder. Another component holder is then placed directly on top of the products.

Special requirements

The construction of interim layers is demanding: On the one hand, the nests have to be designed to accurately accommodate the workpieces. In addition, the base of the component holder must be constructed in such a way that it can be stacked onto the parts below.

Vacuum formed containers



1
*Rotary-stackable
containers*

2
Containers with lids

3
Airmail containers

4
Insertable containers

Blister

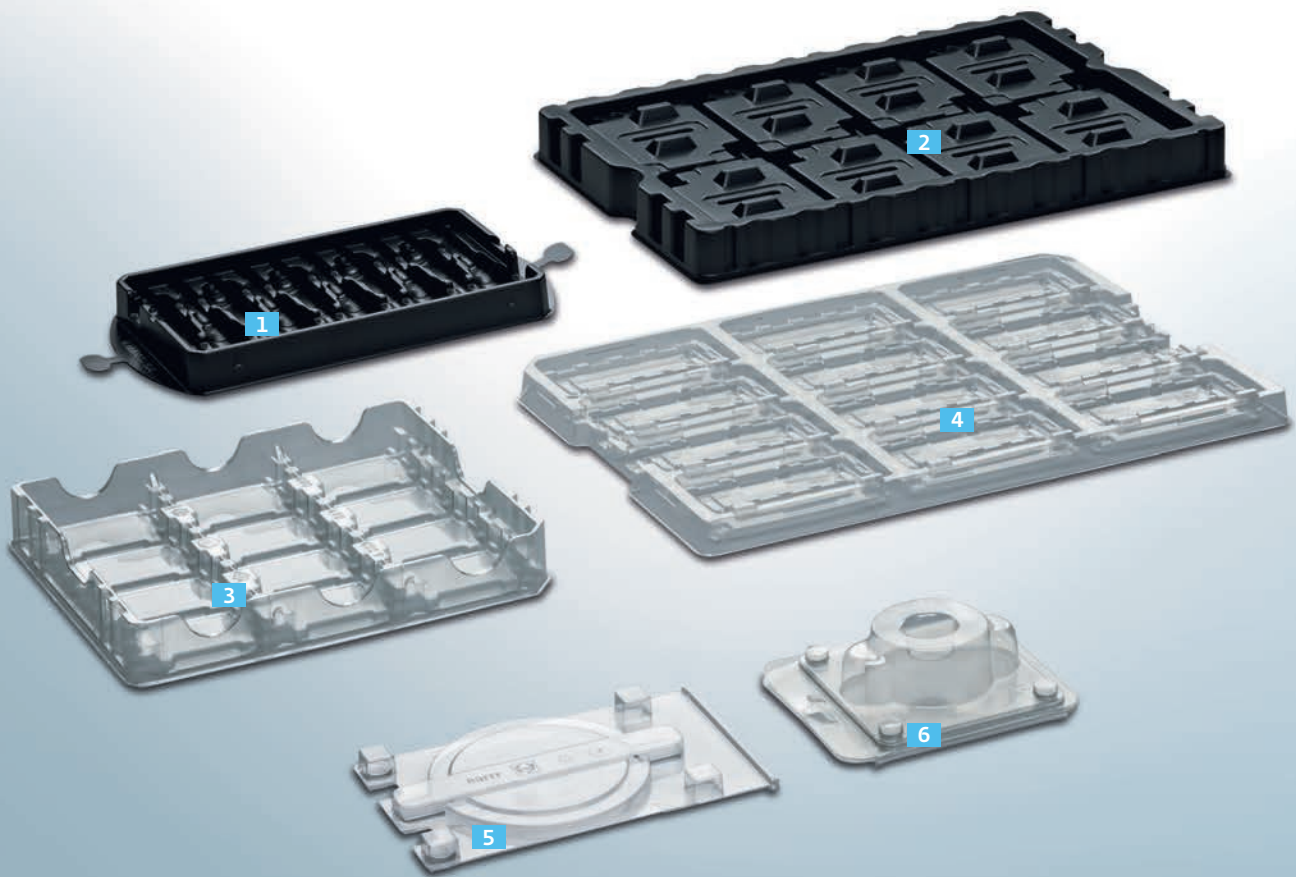

1 2 3 4

*Component holders /
container inserts*

5 6

Foldable packaging

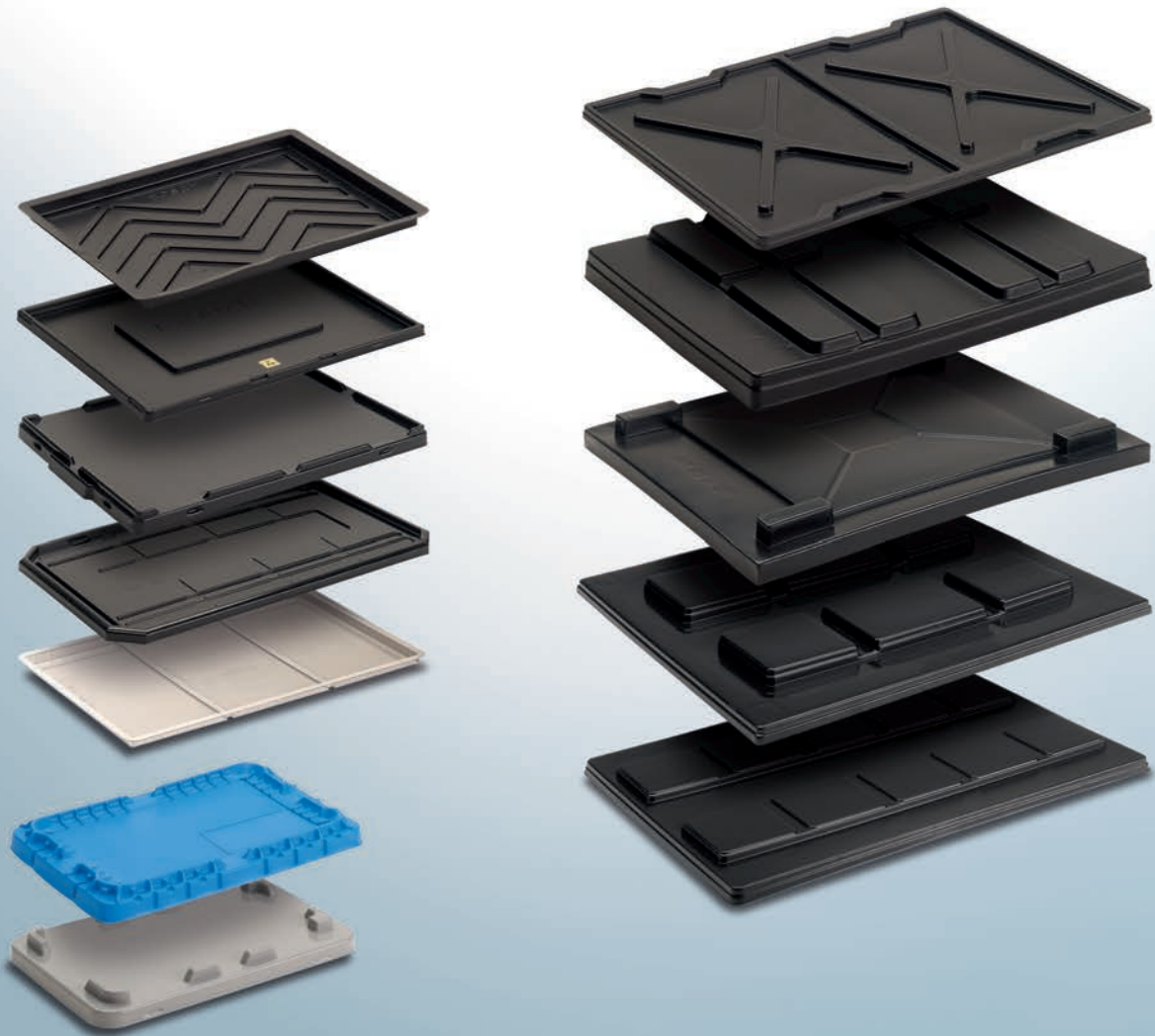

Cover versions:

- Slip lid
- Loose lid / dust cover
- Sliding lid
- Palletc cover

Standard covers

available in the following sizes:

- 300 x 200 mm
- 400 x 300 mm
- 600 x 400 mm
- 800 x 600 mm
- 1200 x 800 mm
- 1200 x 1000 mm

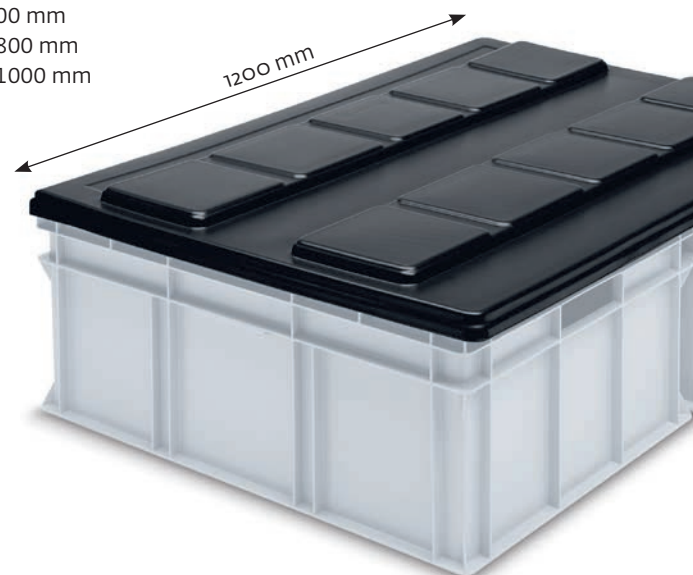

Combined solutions and dividers



1

Dividers

The dividers can be put together in different formats. They are often used to safely store and transport glasses in RAKO containers.

2

Plate separators

The sheets can be individually shaped depending on the size of the plates and container.

3

Divider sheets

Special guide grooves can be injected for flexible use of a container's interior. Divider sheets can therefore be inserted as required.

4

Guide elements

In order to ensure that divider sheets can be accurately inserted into the side walls, vacuum formed gratings can be welded in afterwards.

Transport units



Large load carriers as packaging

The component holders are filled and stacked on top of each other and nested when empty. A foldable pallet container (KLAPA) from Utz serves as external packaging.



Technical information

Tool types

Moulds normally consist of aluminium. For very small series (maximum 50 units), cast resin can also be used. There are two tool designs depending on the application:

Male tools

The shape contour is built up on the tool plate.

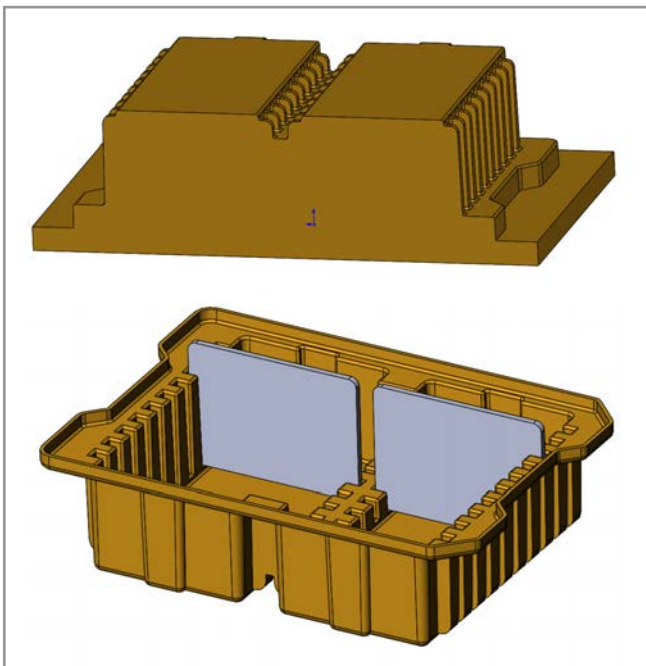

Female tools

The shape contour is recessed in the tool plate.

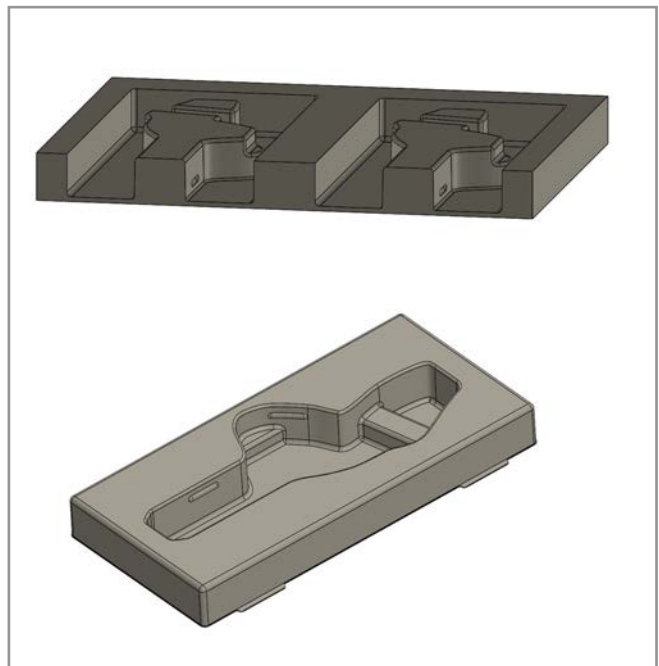

Wall thickness distribution

During the vacuum forming process, the material settles over the tool and is therefore stretched. This results in different wall thicknesses. The moulded part always has one side connected to the tool and one unconnected side.

Male tool

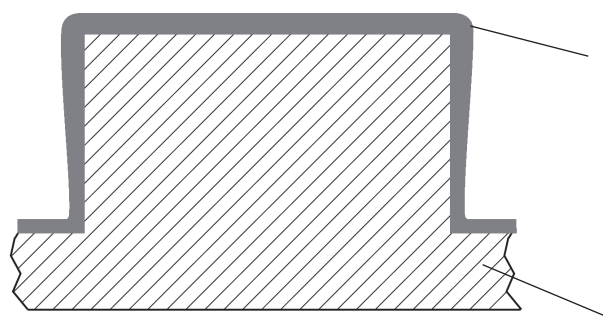

Female tool

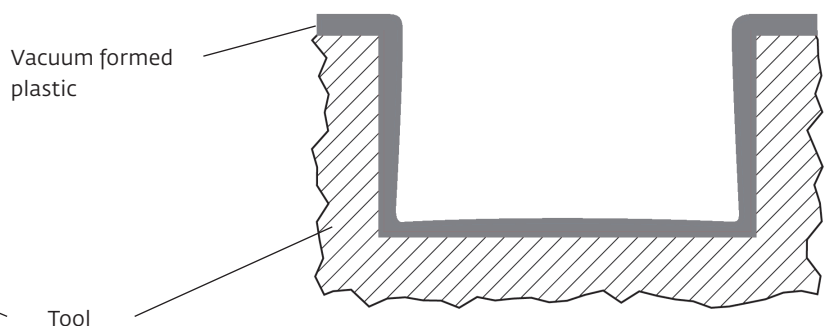

Mould cavity



Horizontal workpiece fixture



Vertical workpiece fixture



Combination carrier, cavity for several different workpieces

Handles

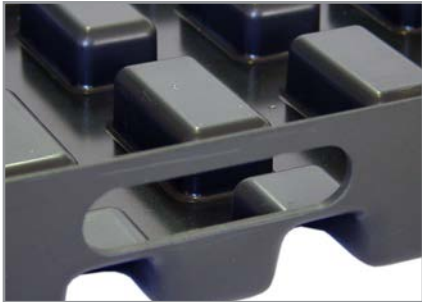

With (milled) handle hole

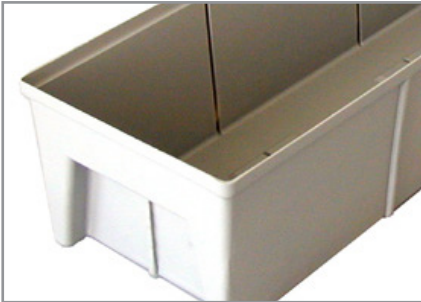

With shell handle



With recess

Anti-twist protection



Bevelled or differently shaped corner

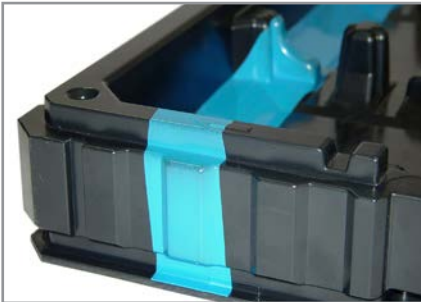

Colour coding, co-extruded colour strips

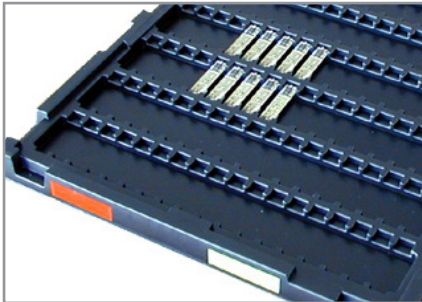

Pad printing



Retracted character

Technical information

Labelling



Writing insert / customer logo raised



Recessed writing insert



Utz seal; Utz article number, recycling seal



Pad printing



Label pocket

Handling



X/Y centering for automated handling



Component holder identification for automated processing

Material

We process all thermoplastics suitable for vacuum forming such as:

Material	Type	Properties	Colour (* = minimum quantities)	Max. temperature consistency
Normal	ABS		black, light grey, all colours*	80° C
	ABS regenerate		black	
	ASA		black, light grey, all colours*	80° C
	PS		black, grey, all colours*	75° C
	PS regenerate		black	75° C
	HDPE		black, light grey, all colours*	75° C
	PE regenerate		black	75° C
	PET-G		transparent, all colours*	70° C
	PP		natural, light grey, all colours*	70° C
	PC		transparent, all colours*	120° C
	PS-PE Blend		black, light grey, all colours*	75° C
PS-PE Blend		black, light grey, all colours*	110° C	
Coated	ABS-TPU (thermoplastic polyurethane coating)	«anti-slip»	black	75° C
Conductive	PS-EL Electrostatically conductive, available in 3 quality levels	Surface resistance $1 \times 10^2 \Omega$ and $< 1 \times 10^4 \Omega$	black	75° C
		Surface resistance $1 \times 10^4 \Omega$ and $< 1 \times 10^6 \Omega$	black (Utz standard quality)	75° C
		Surface resistance $1 \times 10^5 \Omega$ and $< 1 \times 10^7 \Omega$	black	75° C
	PS-EL-CNT Carbon Nano Tubes Electrostatically conductive, available in 3 quality levels	Surface resistance $1 \times 10^2 \Omega$ and $< 1 \times 10^4 \Omega$	black	75° C
		Surface resistance $1 \times 10^4 \Omega$ and $< 1 \times 10^6 \Omega$	black	75° C
		Surface resistance $1 \times 10^5 \Omega$ and $< 1 \times 10^7 \Omega$	black	75° C
	ABS-EL Electrostatically dissipative	Surface resistance $1 \times 10^4 \Omega$ and $< 1 \times 10^6 \Omega$	black	80° C
	ABS permanently antistatic Electrostatically dissipative	Surface resistance $1 \times 10^{10} \Omega$ and $< 1 \times 10^{11} \Omega$	all colours*	80° C
ABS-EL/TPU-EL (coated) Electrostatically dissipative	Surface resistance $1 \times 10^4 \Omega$ and $< 1 \times 10^6 \Omega$	black	75° C	



Component holders in continuous operation

A wide range of applications

Vacuum formed component holders have become indispensable in many areas of modern production, storage and conveying. The component holders produced by Utz are precise, one-of-a-kind units that are designed in accordance with the customer's specifications and the shapes and properties of the parts to be accommodated.

Die castings for gas turbine power plants



Systems for automotive interiors



Electronic parts for pressure measurement technology

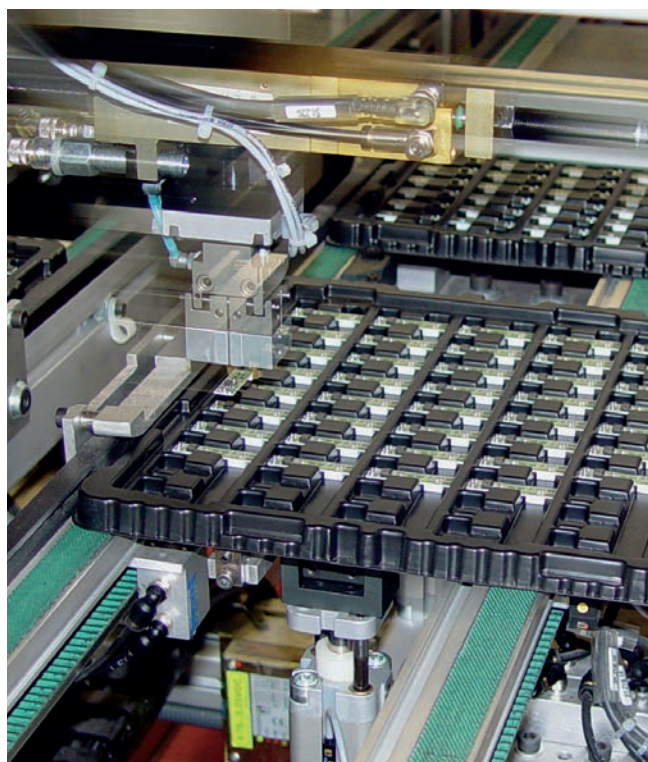

Medical analysis systems

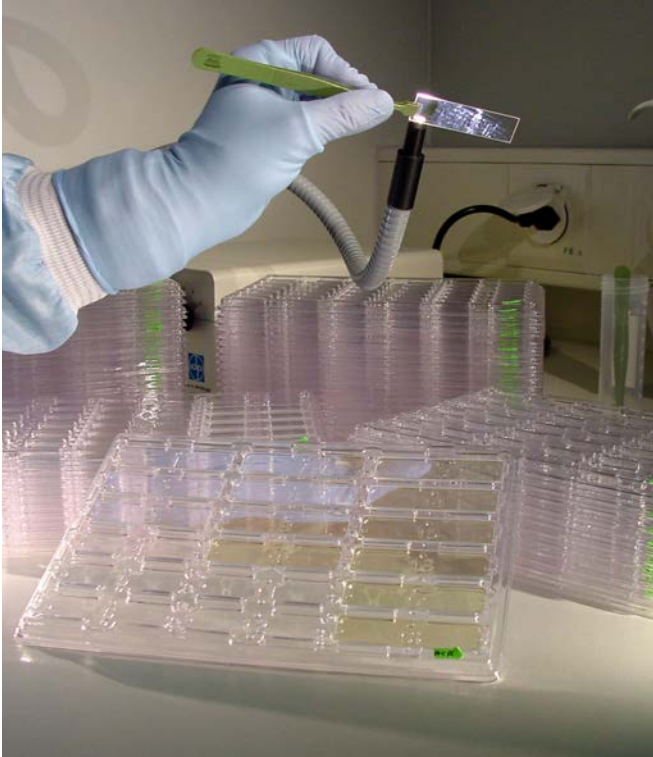

High-pressure pumps



Garden and wire cutters



Components for vehicle construction



Component holders in continuous operation

Components for electric tools

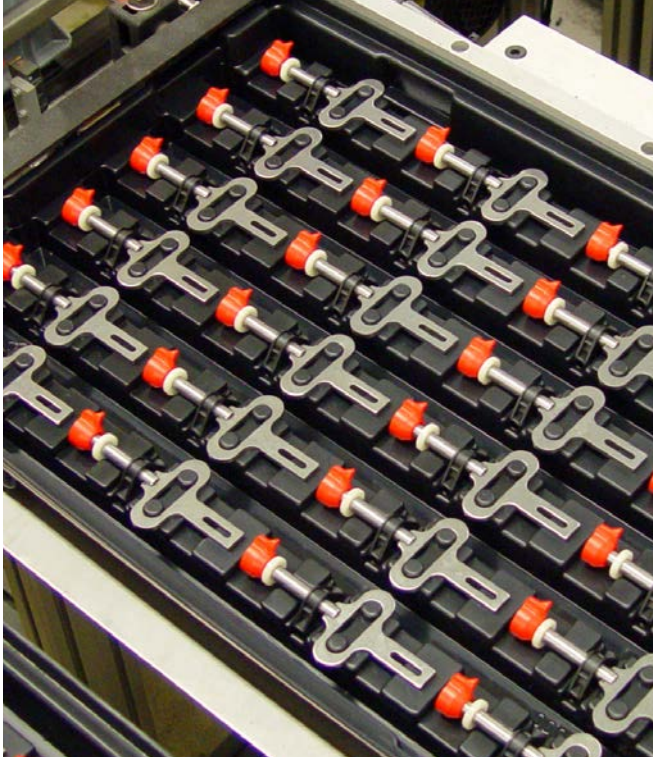

High-voltage components for power generation



Seed cup for the production of agricultural products



Components for fluid systems

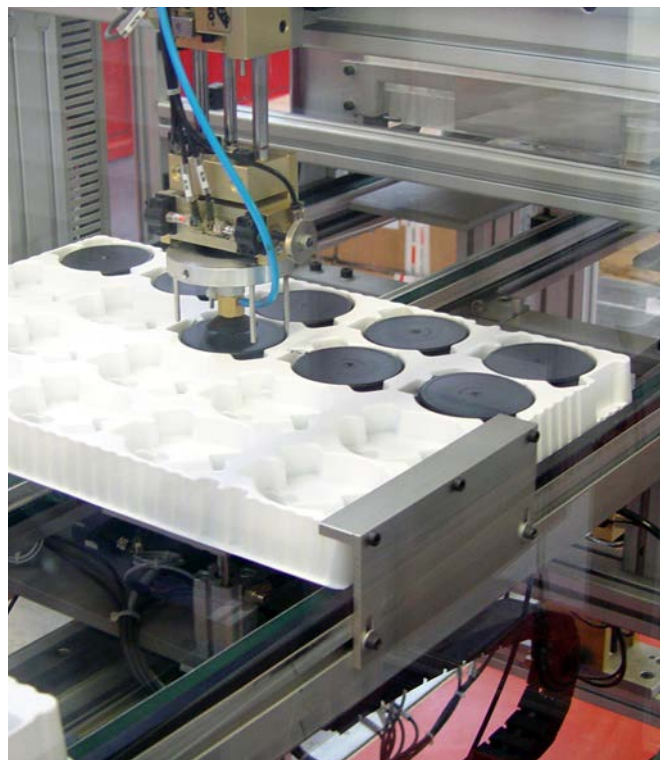

Technical components for the electronics industry



Components for gas pressure regulators



Diesel injection systems



Technical components for fittings construction



